

High-Flow, Manual Gas Pressure Regulators



HF Series

- Compact size with flow rates up to 200 std L/min
- Maximum inlet pressures up to 500 psig (34.4 bar)
- Manually adjustable outlet pressure up to 150 psig (10.3 bar)
- 316L VIM-VAR stainless steel body for ultrahigh-purity applications
- 1/4 in. VCR® metal face seal; 1/4 in. tube butt weld; 1.5 in. and 1.125 in. modular surface-mount end connections

Features

The Swagelok® HF series manual gas pressure regulator features a load spring which interacts with a unique pressure-sensing assembly to precisely control outlet pressure. Outlet pressure is easily adjusted by turning the handle.

- Compact, high-flow design allows close spacing of system components and process lines.
- Innovative, pressure-sensing assembly with welded diaphragm results in low droop, which eliminates the need for adjustment in many systems.
- High-purity design features tied poppet for positive shutoff and metal-to-metal seal to atmosphere and 316L VIM-VAR stainless steel body internally electropolished and finished to 5 $\mu\text{in.}$ (0.13 μm) R_a .



1.5 in. Modular Surface-Mount Model



1.125 in. Modular Surface-Mount Model



Inline Model with Tube Butt Weld End Connections

Inline and 1.5 in. Modular Surface-Mount Models

- Provide flow rates up to 200 std L/min
- Are available in outlet pressures ranging from vacuum to 150 psig (10.3 bar) with four interchangeable, color-coded load springs
- Modular surface-mount regulator with is IGC™ compatible.

Self-Centering Poppet

- Minimizes creep
- Is offered in PCTFE for leak-tight shutoff.

Narrow-Profile Handle

- Permits easy access for pressure adjustments when system components and process lines are closely spaced
- Features both a finger-tip grip and knurled diameter for positive actuation.

1.125 in. Modular Surface-Mount Model

- Is designed for 1.125 in. C-seal and W-seal integrated gas systems
- Provide flow rates up to 160 std L/min
- Is available in two ranges: vacuum to 30 psig (2.0 bar) and vacuum to 60 psig (4.1 bar).

Pressure-Sensing Assembly

- Provides excellent lockup performance with perfluoroelastomer poppet.

Adjustable Outlet Pressure

- Is achieved by fine handle adjustment.
- Optional tamper-resistant handle allows user to set and seal outlet pressure.

Technical Data

Model	Pressure Rating psig (bar)		Temperature Rating °F (°C)		Supply-Pressure Effect (SPE) ^①	Flow Coefficient (C_v)	Flow Rate ^② std L/min	Orifice in. (mm)	Internal Volume in. ³ (cm ³)
	Inlet	Outlet	Operating	Bakeout					
Inline and 1.5 in. modular surface mount	Vacuum to 500 (34.4)	Vacuum to 150 (10.3)	-10 to 150 (-23 to 65)	302 (150)	1.6	0.2	200	0.120 (3.0)	0.32 (5.2) with VCR end connections
1.125 in. modular surface mount	Vacuum to 150 (10.3)	Vacuum to 60 (4.1)	32 to 302 (0 to 150)	32 to 302 (0 to 150)	1.5	0.1	160	0.090 (2.3)	0.172 (2.8)

① The ratio of the change in outlet pressure for every 100 psi change in the inlet pressure.

② With inlet pressure at 100 psig (6.8 bar) and outlet pressure at 30 psig (2.0 bar)

Process Specifications

Refer to Swagelok specifications *Special Cleaning and Packaging (SC-11)* catalog, [MS-06-63](#), and *Ultrapure Process Specification (SC-01)* catalog, [MS-06-61](#), for details on processes, process controls, and process verification.

Cleaning	Assembly and Packaging	Process Designator	Process Specification	Wetted Surface Roughness (R_a)	Testing
Ultrapure cleaning with a continuously monitored, deionized water, ultrasonic cleaning system	Performed in ISO Class 4 work areas; regulators are double bagged and vacuum sealed in cleanroom bags	P	<i>Ultrapure Process Specification (SC-01)</i>	5 $\mu\text{in.}$ (0.13 μm) average, machine finished and electropolished	Inboard helium leak tested to a rate of 1×10^{-9} std cm^3/s
Special cleaning with non-ozone-depleting chemicals	Performed in specially cleaned areas; regulators are individually bagged	P1	<i>Special Cleaning and Packaging (SC-11)</i>		

Materials of Construction

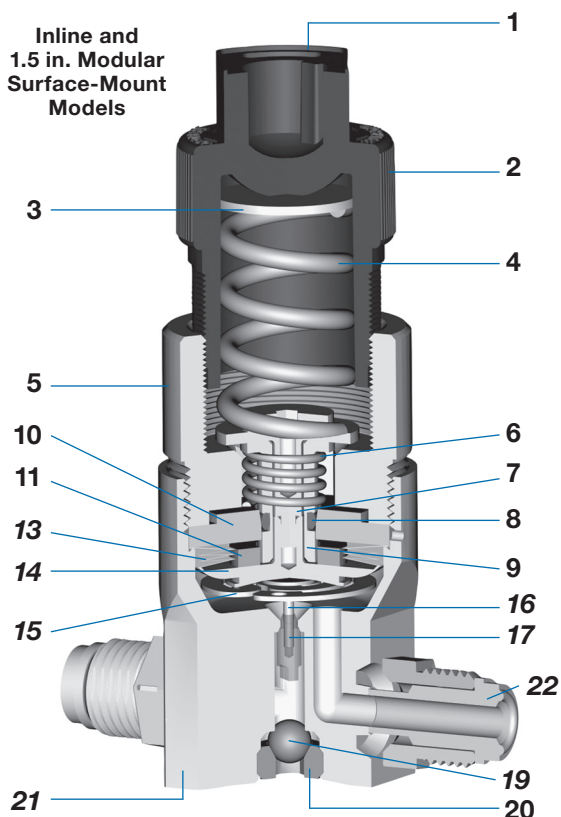

Component	Inline and 1.5 in. Modular Surface-Mount Models	1.125 in. Modular Surface-Mount Model
	Material Grade / ASTM Specification	
1 Label (not shown)	Aluminum	Polypropylene (tamper-resistant handle)
2 Standard handle	Blue nylon	Aluminum 6061-T6 / B211
Optional handle	Aluminum 6061-T6 / B211	—
Set screw (not shown)	—	Alloy steel / ANSI 18.3 (tamper-resistant handle)
3 Load disk	S17400 SS / A564	Polyetherimide / D5205
4 Load spring	S17700 SS / A313	
5 Bonnet nut	Silver-plated 316 SS / A479	
6 Balance spring	S17700 SS / A313	
7 Damper shaft	316 SS / A479	—
8 O-ring	Fluorocarbon FKM	
9 O-ring catch	Brass 360 / B16	—
10 Bonnet	S17400 SS / A564	
11 Backup ring	Brass 360 / B16	—
12 Return disk	—	Brass 360 / B16
13 Diaphragm	Alloy 625 / AMS 5879	
14 Face plate	316L SS VIM-VAR / SEMI F20 Ultrapure ^①	—
15 Poppet-retaining wafer	Alloy X-750 / B637	—
16 Stem	316L SS / A479	
17 Poppet	PCTFE	Perfluoroelastomer FFKM
18 Poppet core	—	316L SS / A479
19 Poppet port seal	Alloy C-276 / B574	—
20 Poppet port plug	316 SS / A479	—
21 Body	316L SS VIM-VAR / SEMI F20 Ultrapure ^①	
22 Welded end connections	316L SS VIM-VAR / SEMI F20 Ultrapure ^①	—

Wetted components listed in *italics*.
 ① 20 % minimum elongation allowed.

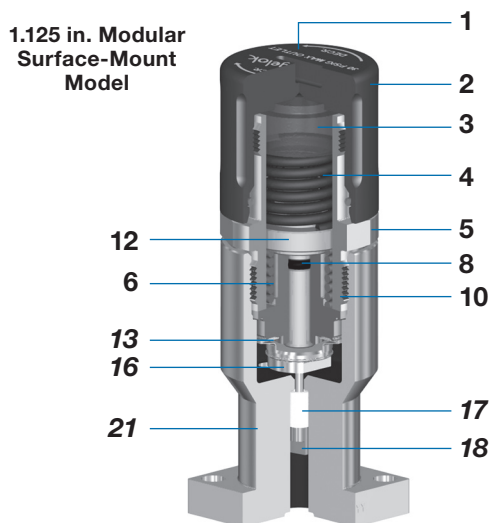

Operating Performance

Inline and 1.5 in. Modular Surface-Mount Models

Load Spring Range at Maximum Inlet and Outlet Pressures

The operating range for each load spring includes the area below each line.

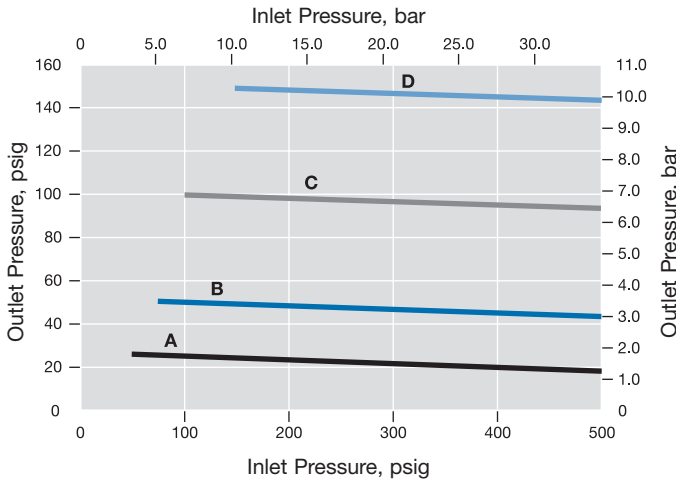

Load Spring	Outlet Pressure Range psig (bar)	Spring Color
A	Vacuum to 25 (1.7)	Red
B	5 to 50 (0.34 to 3.4)	White
C	10 to 100 (0.68 to 6.8)	Blue
D	20 to 150 (1.3 to 10.3)	Yellow

1.125 in. Modular Surface-Mount Model

Average Lockup Pressure

Example: For a flow rate of 200 std cm³/min, after downstream flow is shut off, the change in outlet pressure is approximately 0.9 psi (0.06 bar).

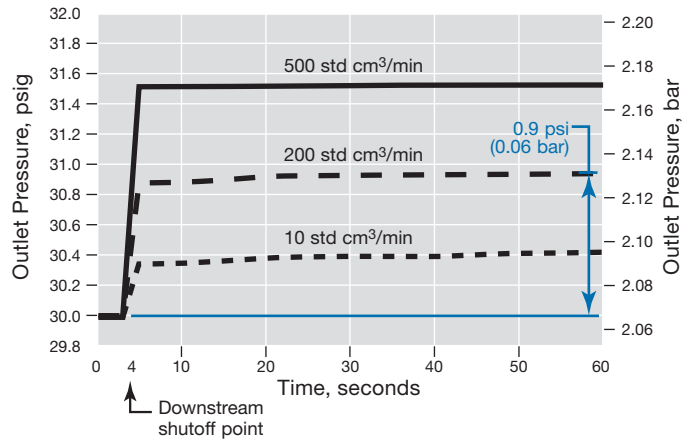

Flow Data

The graphs illustrate the change or “droop” in outlet pressure as the flow rate increases and the inlet pressure decreases.

Inline and 1.5 in. Modular Surface-Mount Models

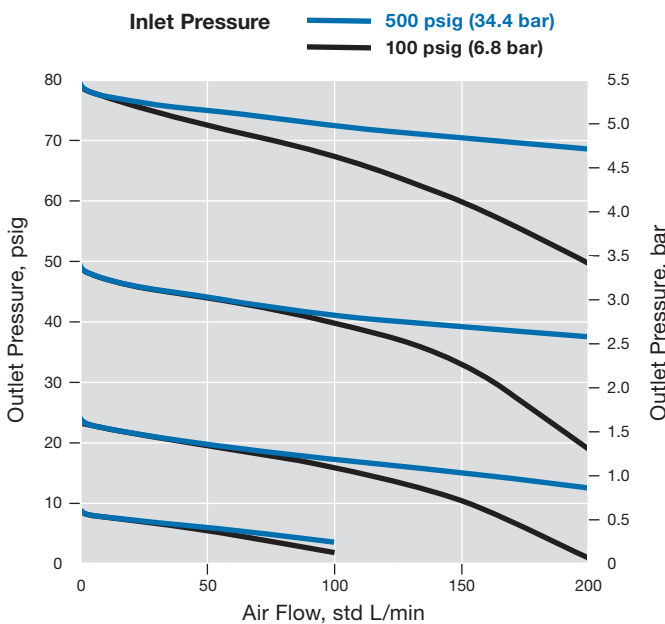

1.125 in. Modular Surface-Mount Model

Example: For an outlet pressure of 30 psig as the flow rate increases from 10 to 60 std L/min, the differential outlet pressure, or droop, is approximately 3.5 psi (0.24 bar).

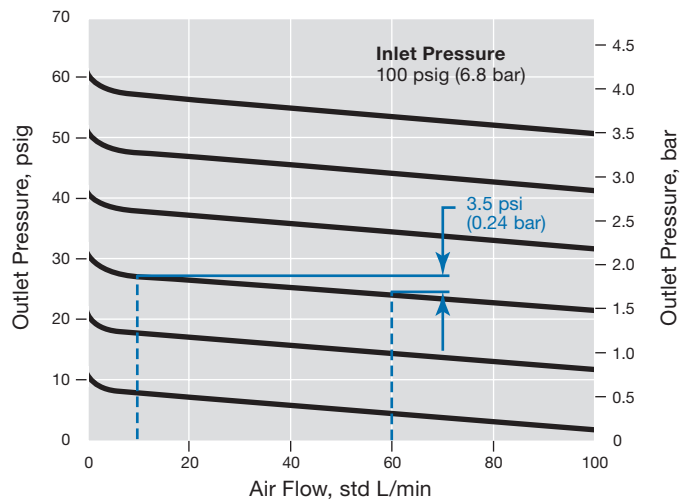

Dimensions

Dimensions, in inches (millimeters), are for reference only and are subject to change.

Inline Models

Standard Handle

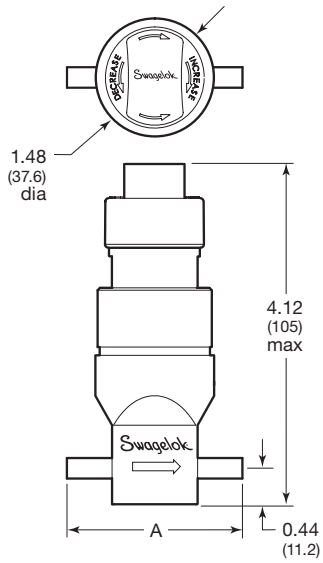

Tube Butt Weld End Connections

Low-Torque Handle

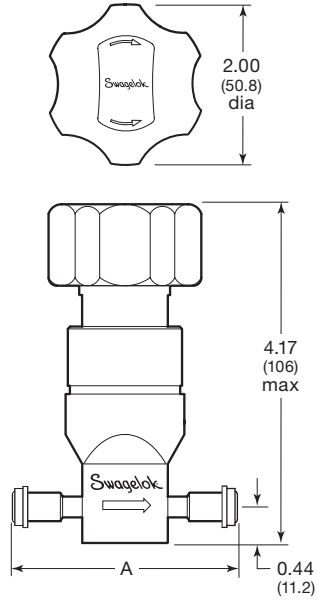

VCR End Connections

Bottom

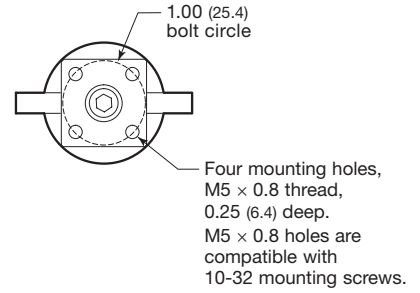

End Connection	A, in. (mm)
Butt weld	2.15 (54.6)
VCR, short gland	2.78 (70.6)
VCR, long gland	3.70 (94.0)

Modular Surface-Mount Models

1.50 in. Platform

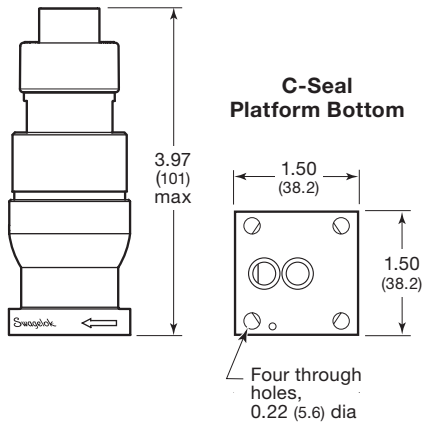

1.125 in. Platform

Standard Handle

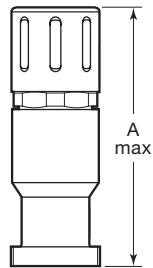

C-Seal Platform Bottom

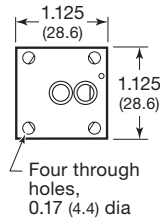

W-Seal Platform Bottom

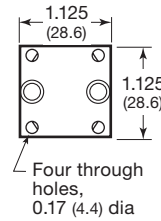

Handle	A, in. (mm)
Standard	3.66 (93.0)
Tamper resistant	3.57 (90.7)

Ordering Information

Inline and 1.5 in. Modular Surface-Mount Models

To order a complete assembly, order a regulator and a spring kit. Regulators are stocked with narrow-profile blue nylon handles and without spring kits.

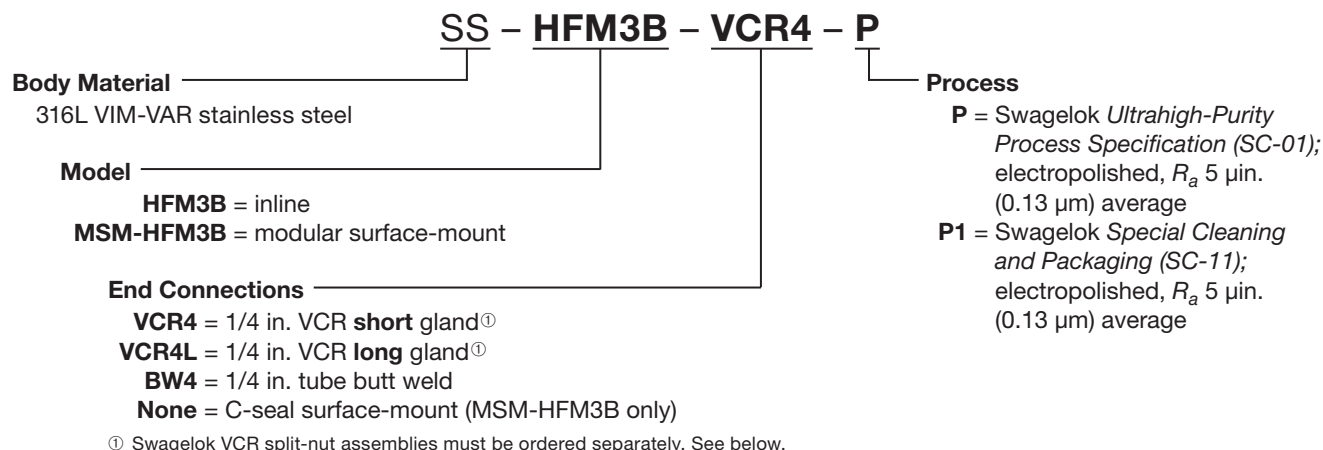

Spring Kits

Spring kits include a load spring, load disk, label, and installation instructions. To order, select the spring kit ordering number based on the desired outlet pressure range of the regulator.



Outlet Pressure Range psig (bar)	Spring Kit Ordering Number
Vacuum to 25 (1.7)	177-13K-HFM-A
5 to 50 (0.34 to 3.4)	177-13K-HFM-B
10 to 100 (0.68 to 6.8)	177-13K-HFM-C
20 to 150 (1.3 to 10.3)	177-13K-HFM-D ^①

^① See **Low-Torque Handle**, page 7.

Swagelok VCR Split-Nut Assemblies

Swagelok VCR split-nut technology offers:

- Flexibility of inventory
- Shorter end-to-end dimensions
- Rotatable, nonwelded S17400 end connections.

When ordering a regulator with VCR end connections, VCR split-nut assemblies must be ordered separately. VCR split-nut assemblies are field assembled. To order, select the ordering number for the male or female assemblies.

Male split-nut assembly
ordering number:
SS-4-VCR-4-SN

Female split-nut assembly
ordering number:
SS-4-VCR-1-SN



Ordering Information

1.125 in. Modular Surface-Mount Model

Build a regulator ordering number by combining the designators in the sequence shown.

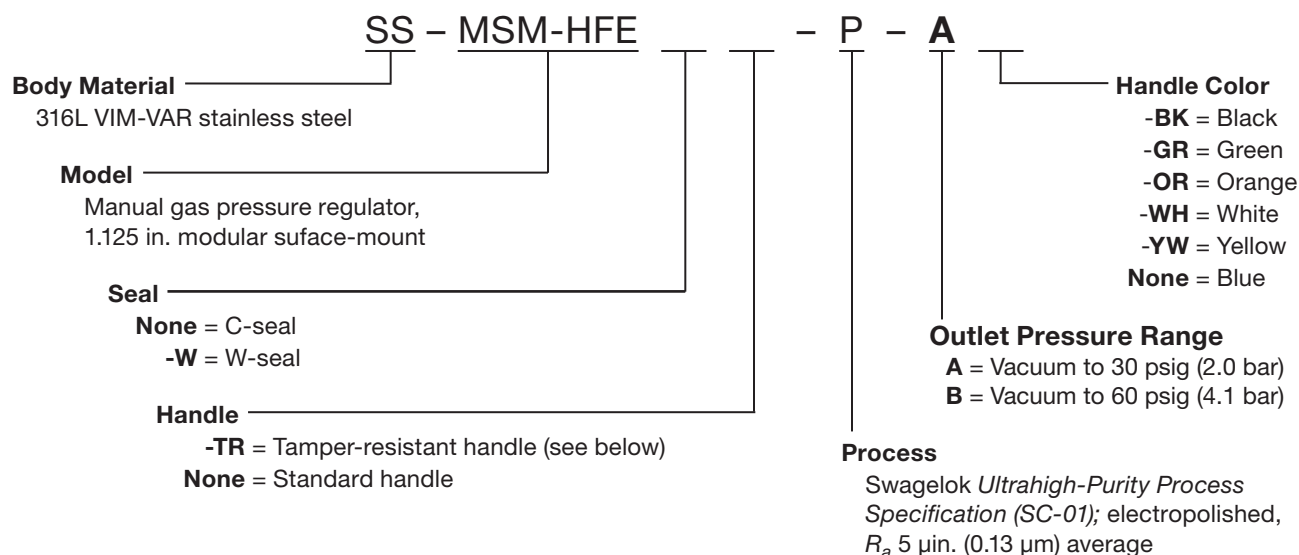

Options and Accessories

Inline and 1.5 in. Modular Surface-Mount Models

Factory-Installed Load Springs

Regulators can be ordered with a *factory-installed* load spring. To order, add the spring designator to the regulator ordering number.

Example:
SS-HFM3B-VCR4-P-A

Outlet Pressure Range psig (bar)	Spring Designator
Vacuum to 25 (1.7)	-A
5 to 50 (0.34 to 3.4)	-B
10 to 100 (0.68 to 6.8)	-C
20 to 150 (1.3 to 10.3)	-D

Aluminum Handles

Narrow-Profile Handle

The standard, narrow-profile handle is also available in aluminum with a choice of seven epoxy-coated colors.

To order a *factory-installed* narrow-profile aluminum handle on an HF series manual regulator, add the handle color designator to the regulator ordering number.

Example: SS-HFM3B-VCR4-P-BK

Handle Color	Designator
Black	-BK
Blue	-BL
Green	-GR
Orange	-OG
Red	-RD
White	-WH
Yellow	-YW

Low-Torque Handle

An optional six-lobed handle is available to provide a lower actuation torque. The low-torque handle is epoxy-coated aluminum and is available in seven colors.

The low-torque handle is suitable for use with the 20 to 150 psig (1.3 to 10.3 bar) spring kit. The handle has a diameter of 2.00 in. (50.8 mm), as shown on page 5, and is not recommended for use with modular surface-mount regulators.

To order a *factory-installed* low-torque aluminum handle, insert **L** and add the color designator to the regulator ordering number as shown.

Example: SS-HFML3B-VCR4-P-BK

1.125 in. Modular Surface-Mount Model

Tamper-Resistant Handle

- **Set**—outlet pressure is adjusted using a set screw in the top of the handle.
- **Seal**—handle sticker is applied to prevent access to the set screw.



Maintenance Kits

Inline and 1.5 in. Modular Surface-Mount Models

Poppet Kits

A poppet kit includes one poppet, poppet port seal, and installation instructions.

Ordering number: **MS-3K-HFM3**



Poppet Tool

A poppet replacement tool is needed for poppet installation.

Ordering number: **MS-TOOL-HFM3**



Oxygen Service Hazards

For more information about hazards and risks of oxygen-enriched systems, refer to Swagelok *Oxygen System Safety* technical report, [MS-06-13](#).

Safe Product Selection

When selecting a product, the total system design must be considered to ensure safe, trouble-free performance. Function, material compatibility, adequate ratings, proper installation, operation, and maintenance are the responsibilities of the system designer and user.

⚠ WARNING

Do not mix/interchange Swagelok products or components not governed by industrial design standards, including Swagelok tube fitting end connections, with those of other manufacturers.

Warranty Information

Swagelok products are backed by The Swagelok Limited Lifetime Warranty. For a copy, visit swagelok.com or contact your authorized Swagelok representative.